



**PROPRIETARY NOTE**

THIS SPECIFICATION IS THE PROPERTY OF BOE HYDIS AND SHALL NOT BE REPRODUCED OR COPIED WITHOUT THE WRITTEN PERMISSION OF BOE HYDIS AND MUST BE RETURNED TO BOE HYDIS UPON ITS REQUEST

**TITLE : HV121P01-100**  
**Preliminary Product Specification**  
**Rev. P0**

**BOE HYDIS TECHNOLOGY**

SPEC. NUMBER  
TD-0004549

PRODUCT GROUP  
TFT LCD

REV.  
P0

ISSUE DATE  
06.05.30

PAGE  
1 OF 27



**PRODUCT GROUP**

REV

ISSUE DATE

TFT LCD PRODUCT

P0

06.05.03

**REVISION HISTORY**

REV.	ECN NO.	DESCRIPTION OF CHANGES	DATE	PREPARED
P0	-	Initial Release	06.05.03	H.R.PARK

SPEC. NUMBER

SPEC TITLE  
HV121P01-100 Preliminary Product Specification

PAGE  
2 OF 27



# PRODUCT GROUP

REV

ISSUE DATE

TFT LCD PRODUCT

P0

06.05.03

## Contents

No	Item	Page
1.0	General Description	4
2.0	Absolute Maximum ratings	6
3.0	Electrical specifications.	7
4.0	Optical specifications.	9
5.0	Interface Connection	13
6.0	Signal Timing Specification	16
7.0	Signal Timing waveforms	16
8.0	Input Signals, Display Colors & Gray Scale of Colors	18
9.0	Power Sequence	19
10.0	Mechanical Characteristics	20
11.0	Reliability Test	21
12.0	Handling & Cautions.	22
13.0	Packing information	23
14.0	Label	24
Appendix	Outline drawing (Front and Rear)	26

SPEC. NUMBER

SPEC TITLE

HV121P01-100 Preliminary Product Specification

PAGE

3 OF 27

**1.0 GENERAL DESCRIPTION**

**1.1 Introduction**

HV121P01-100 is a color active matrix TFT LCD module using amorphous silicon TFT's (Thin Film Transistors) as an active switching devices. This module has a 12.1 inch diagonally measured active area with SXGA+ resolutions (1400 horizontal by 1050 vertical pixel array). Each pixel is divided into RED, GREEN, BLUE dots which are arranged in vertical stripe and this module can display 262,144 colors. The TFT-LCD panel used for this module is a low reflection and higher color type. Therefore, this module is suitable for Notebook PC. The DC/AC inverter for back-light driving is not built in this model.

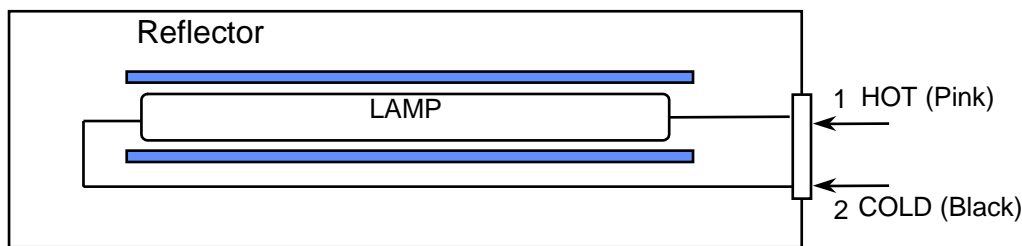
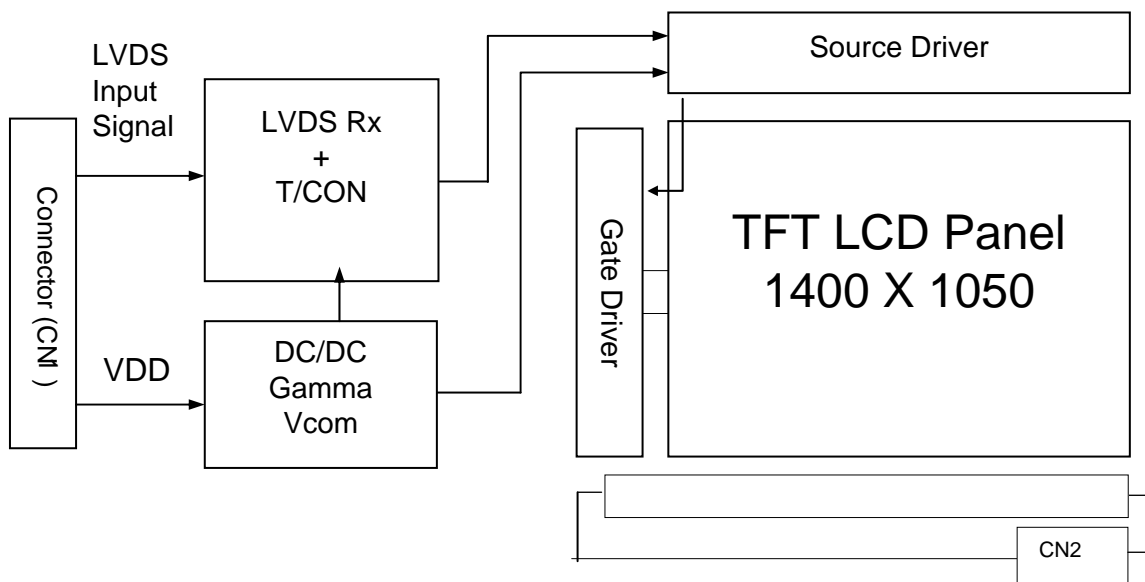

*Note)* The output of the inverter may change according to the material of the reflector.

**1.2 Features**

- 12.1" SXGA + AFFS
- Thin and light weight
- 3.3 V power supply
- 1 Channel LVDS Interface
- Single CCFL (Bottom side/Horizontal Direction)
- 262,144 colors
- Data enable signal mode
- Front mounting frame
- Green Product (RoHS)
- On Board EDID chip
- High contrast ratio

**1.3 General Specification**

The followings are general specifications at the model HV121P01-100. (listed in Table 1.)

<Table 1. General Specifications>

Parameter	Specification	Unit	Remarks
Active area	245.70 (H) X 184.275 (V) (12.1" diagonal)	mm	
Number of pixels	1400(H) × 1050(V)	pixels	
Pixel pitch	0.1755(H) × 0.1755(V)	mm	
Pixel arrangement	RGB Vertical stripe		
Display colors	262,144	colors	
Display mode	Normally Black		
Dimensional outline	270.0 ±0.5(H) × 199.0 ±0.5(V) × 4.8 ±0.3@Lamp	mm	Note 1.
Weight	305 g (typ.), 315 g (Max.)	g	
Surface treatment	AG(H40%)/2H		
Back-light	Bottom edge side, 1-CCFL type		Note 2.
Power consumption	$P_D$ : 0.9	W	
	$P_{BL}$ : 3.2	W	
	$P_{total}$ : 4.1	W	

Note 1. : LCM Height 4.8 [mm] typical (lamp area) and 6.7 [mm] typical (Pouch area)

2. : CCFL (Cold Cathode Fluorescent Lamp)

**2.0 ABSOLUTE MAXIMUM RATINGS**

The followings are maximum values which, if exceed, may cause faulty operation or damage to the unit. The operational and non-operational maximum voltage and current values are listed in Table 2.

< Table 2. Absolute Maximum Ratings>

Ta=25+/-2°C

Parameter	Symbol	Min.	Max.	Unit	Remarks
Power Supply Voltage	V <sub>DD</sub>	-0.3	4.0	V	
Logic Supply Voltage	V <sub>IN</sub>	-0.3	V <sub>DD</sub> +0.3	V	
Lamp Current	I <sub>L</sub>	3.0	6.0	mArms	(1)
Lamp frequency	F <sub>L</sub>	30	80	kHz	
Operating Temperature	T <sub>OP</sub>	0	+50	°C	(2)
Operating Humidity	RH <sub>OP</sub>	-	80	%	
Storage Temperature	T <sub>SP</sub>	-20	+60	°C	
Storage Humidity	RH <sub>ST</sub>	-	90	%	

Note (1) Permanent damage to the device may occur if maximum values are exceeded  
Functional operation should be restricted to the condition described under normal operating conditions.

Note (2) Temperature and relative humidity range are shown in the figure below.  
95 % RH Max. ( 40 °C ≥ Ta)  
Maximum wet - bulb temperature at 39 °C or less. (Ta > 40 °C) No condensation.

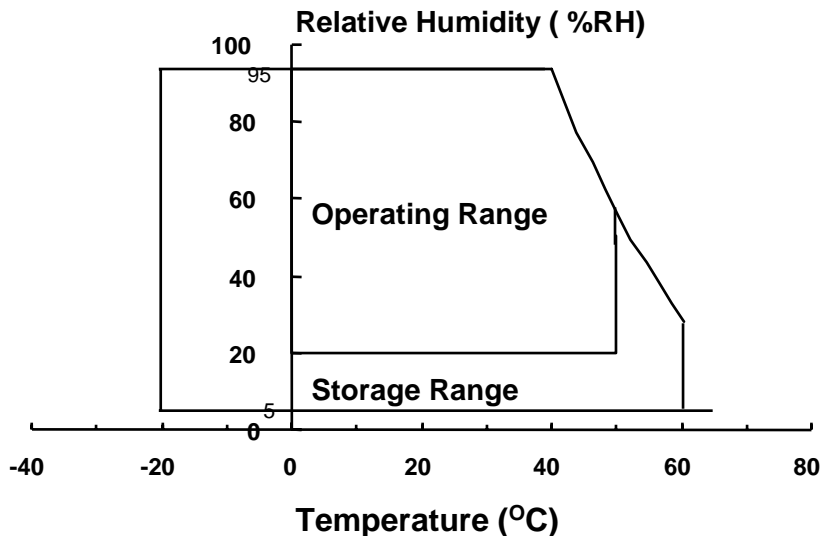

### 3.0 ELECTRICAL SPECIFICATIONS

#### 3.1 Electrical Specifications

&lt; Table 3. Electrical specifications &gt;

Parameter		Min.	Typ.	Max.	Unit	Remarks
Power Supply Voltage	$V_{DD}$	3.0	3.3	3.6	V	Note1
Permissible Input Ripple Voltage	$V_{RF}$	-	-	100	mV	At $V_{DD} = 3.3V$
Power Supply Current	$I_{DD}$	-	270	-	mA	Note1
High Level Differential Input Signal Voltage	$V_{IH}$	-	-	+ 100	mV	$V_{cm} = 1.2 V$ typ
Low Level Differential Input Signal Voltage	$V_{IL}$	- 100	-	-		
Back-light Lamp Voltage	$V_{BL}$	680	580	560	$V_{rms}$	Note2
Back-light Lamp Current	$I_{BL}$	2.0	5.5	6.0	mA	
Back-light Lamp operating Frequency	$F_L$	40	60	80	KHz	One Lamp , Note3
Lamp Start Voltage		1,050	-	-	$V_{rms}$	At $T_a = 25^{\circ}C$ Note 4
		1,310	-	-		At $T_a = 0^{\circ}C$ Note 4
Back Light Life		10,000	-	-	Hrs	At $I_{BL} = 6.0 mA$ , Max. Note5
Power Consumption	$P_D$	-	0.9	-	W	Note1
	$P_{BL}$	-	3.2	-	W	Note6, $I_{BL} = 5.5mA$
	$P_{total}$	-	4.1	-	W	



# PRODUCT GROUP

REV

ISSUE DATE

TFT LCD PRODUCT

P0

06.05.03

- Notes :
- The supply voltage is measured and specified at the interface connector of LCM. The current draw and power consumption specified is for 3.3V at 25°C. The test pattern of power supply current
    - Typ : Window XP pattern @ 50Hz
    - Max : Gray 28 @ vertical 2 skip line pattern
  - Reference value, which is measured with Samsung Electric SIC-180 Inverter. (VBL Min is value at IBL Min and VBL Max is value at IBL Max)
  - The lamp frequency should be selected as different as possible from the horizontal synchronous frequency and its harmonics to avoid interference which may cause line flow on the display.
  - For starting the backlight unit, the output voltage of DC/AC's transformer should be larger than the minimum lamp starting voltage. (1,050 Vrms at 25 °C, 1,310 Vrms at 0 °C)  
If an inverter has shutdown function it should keep its output for more than 1 second even if the lamp connector open. Otherwise the lamps may not to be turned on.
  - End of Life shall be determined by the time when any of the following is satisfied under continuous lighting at 25°C and IBL = 6.0[mA] Max Only.
    - Intensity drops to 50% of the Initial Value.
  - The typical value is calculated value for reference (VBL × IBL).  
Max value adds a 10 % tolerance of typical value of Back light power.

SPEC. NUMBER

SPEC TITLE

HV121P01-100 Preliminary Product Specification

PAGE

8 OF 27



## 4.0 OPTICAL SPECIFICATION

### 4.1 Overview

The test of Optical specifications shall be measured in a dark room (ambient luminance  $\leq 1$  lux and temperature =  $25 \pm 2^\circ\text{C}$ ) with the equipment of Luminance meter system (Goniometer system and TOPCONE BM-5) and test unit shall be located at an approximate distance 50cm from the LCD surface at a viewing angle of  $\Theta$  and  $\Phi$  equal to  $0^\circ$ . We refer to  $\Theta=0$  ( $=\Theta_3$ ) as the 3 o'clock direction (the "right"),  $\Theta=90$  ( $=\Theta_{12}$ ) as the 12 o'clock direction ("upward"),  $\Theta=180$  ( $=\Theta_9$ ) as the 9 o'clock direction ("left") and  $\Theta=270$  ( $=\Theta_6$ ) as the 6 o'clock direction ("bottom"). While scanning  $\Theta$  and/or  $\Phi$ , the center of the measuring spot on the Display surface shall stay fixed. The backlight should be operating for 30 minutes prior to measurement... VDD shall be  $3.3 \pm 0.3\text{V}$  at  $25^\circ\text{C}$ . Optimum viewing angle direction is 6 o'clock.

### 4.2 Optical Specifications

<Table 4. Optical Specifications>

Parameter		Symbol	Condition	Min.	Typ.	Max.	Unit	Remark		
Viewing Angle range	Horizontal	$\Theta_3$	CR > 10	-	89	-	Deg.	Note 1		
		$\Theta_9$		-	89	-	Deg.			
	Vertical	$\Theta_{12}$		-	89	-	Deg.			
		$\Theta_6$		-	89	-	Deg.			
Luminance Contrast ratio		CR	$\Theta = 0^\circ$	-	500:1	-		Note 2		
Center Luminance of White	1 Point	$Y_w$	$\Theta = 0^\circ$ IBL = 5.5mA	-	190	-	cd/m <sup>2</sup>			
White Luminance uniformity	5 Points	$\Delta Y5$		80	-	-	%			
White Chromaticity		$W_x$	$\Theta = 0^\circ$	0.273	0.303	0.333		Note 3		
		$W_y$		0.298	0.328	0.358				
Reproduction of color	Red	$R_x$		-	TBD	-				
		$R_y$		-	TBD	-				
	Green	$G_x$		-	TBD	-				
		$G_y$		-	TBD	-				
	Blue	$B_x$		-	TBD	-				
		$B_y$		-	TBD	-				
Response Time	Rise	$T_r$		Ta = $25^\circ\text{C}$ $\Theta = 0^\circ$	-	30	-		ms	
	Decay	$T_d$								
Color Reproduction		-	-	-	43	-	%			
Cross Talk		CT	$\Theta = 0^\circ$	-	-	2.0	%			

- Notes :
1. Viewing angle is the angle at which the contrast ratio is greater than 10. The viewing angles are determined for the horizontal or 3, 9 o'clock direction and the vertical or 6, 12 o'clock direction with respect to the optical axis which is normal to the LCD surface (see FIGURE1 as below).
  2. Contrast measurements shall be made at viewing angle of  $\Theta = 0$  and at the center of the LCD surface. Luminance shall be measured with all pixels in the view field set first to white, then to the dark (black) state .  
Luminance Contrast Ratio (CR) is defined mathematically as  $CR = \text{Luminance when displaying a white raster} / \text{Luminance when displaying a black raster}$ .
  3. The color chromaticity coordinates specified in Table 4. shall be calculated from the spectral data measured with all pixels first in red, green, blue, and white. Measurements shall be made at the center of the panel.

**4.3 Optical measurements**

**Figure 1. Measurement Set Up**

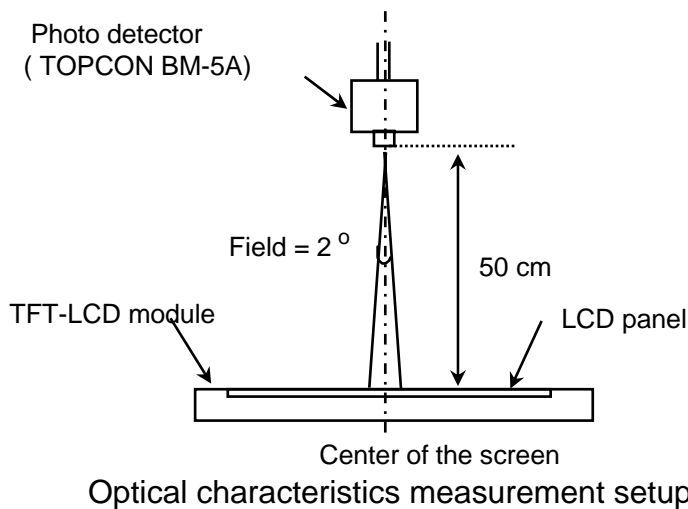

**Figure 2. White Luminance (Center) and Uniformity Measurement Locations (5 points)**

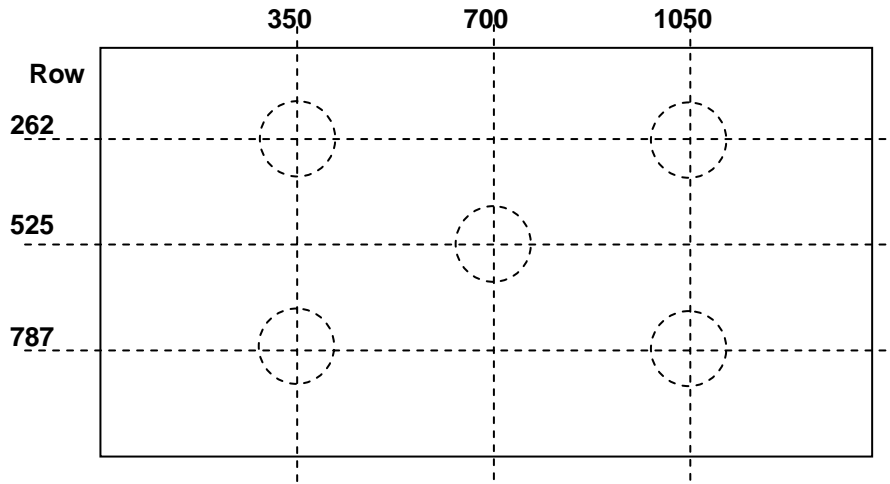

White luminance : Center Luminance of white is defined as luminance values of center 1 point. Luminance shall be measured with all pixels in the view field set first to white. This measurement shall be taken at the locations shown in FIGURE 2.

Uniformity of 5 points : The White luminance uniformity on LCD surface is expressed as :  $\Delta Y5 = \text{Minimum Luminance of five points} / \text{Maximum Luminance of five points}$  (see FIGURE 2)

**Figure 3. Response Time Testing**

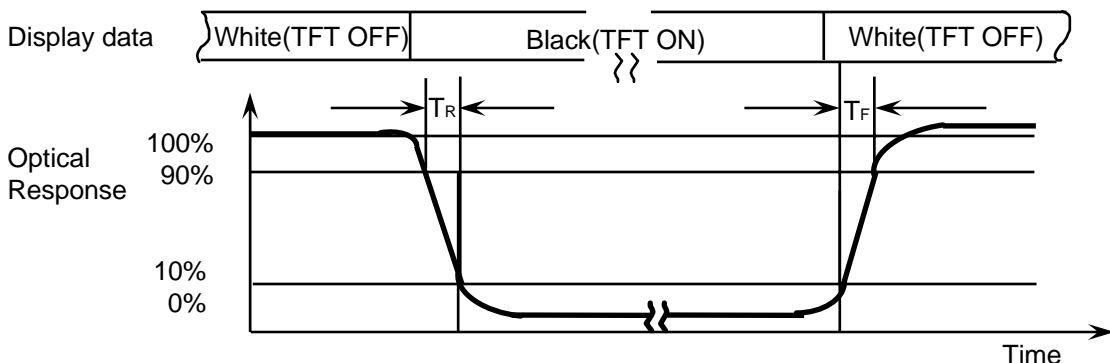

The electro-optical response time measurements shall be made as shown in FIGURE 3 by switching the data input signal ON and OFF. The times needed for the luminance to change from 10% to 90% is  $T_d$  and 90% to 10% is  $T_r$ .

**Figure 4. Cross Modulation Test Description**

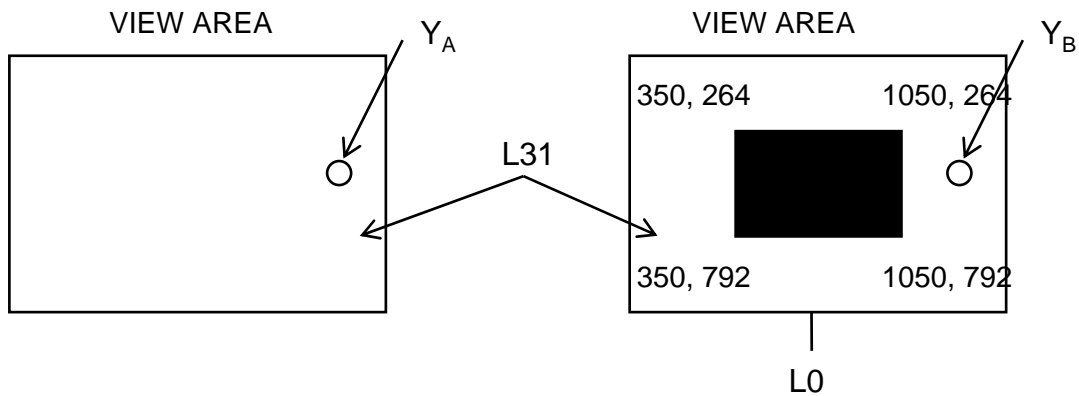

Test point of  $Y_A / Y_B$  : Point of  $Y_B$  (1225, 525)

$$\text{Cross-Talk (\%)} = \left| \frac{Y_B - Y_A}{Y_B} \right| \times 100$$

Where:

$Y_A$  = Initial luminance of measured area (cd/m<sup>2</sup>)

$Y_B$  = Subsequent luminance of measured area (cd/m<sup>2</sup>)

The location measured will be exactly same position in both patterns

Cross-Talk of one area of the LCD surface by another shall be measured by comparing the luminance ( $Y_A$ ) of a 25mm diameter area, with all display pixels set to a gray level, to the luminance ( $Y_B$ ) of that same area when any adjacent area is driven dark (Refer to FIGURE 4).

## 5.0 INTERFACE CONNECTION.

### 5.1 Electrical Interface Connection

CN 1 : Interface connector : DF19L-20P-1H (Hirose)

User side connector : DF19G-20S-1C (Hirose)

<Table 5. Pin Assignments for the Interface Connector>

Terminal	Symbol	Functions
1	VDD	Power Supply : +3.3V (typical)
2	VDD	Power Supply : +3.3V (typical)
3	GND	Ground
4	GND	Ground
5	RIN0-	-LVDS differential data input (R0~R5,G0)
6	RIN0+	+LVDS differential data input (R0~R5,G0)
7	GND	Ground
8	RIN1-	-LVDS differential data input (G1~G5,B0,B1)
9	RIN1+	+LVDS differential data input (G1~G5,B0,B1)
10	GND	Ground
11	RIN2-	-LVDS differential data input (B2~B5,HS,VS,DE))
12	RIN2+	+LVDS differential data input (B2~B5,HS,VS,DE)
13	GND	Ground
14	CLKIN-	-LVDS differential Clock input
15	CLKIN+	+LVDS differential Clock input
16	GND	Ground
17	EDID 3.3V	EDID 3.3V
18	VSS	Ground
19	EDID Clk	EDID Clk
20	EDID Data	EDID Data

**5-2. LVDS Interface**

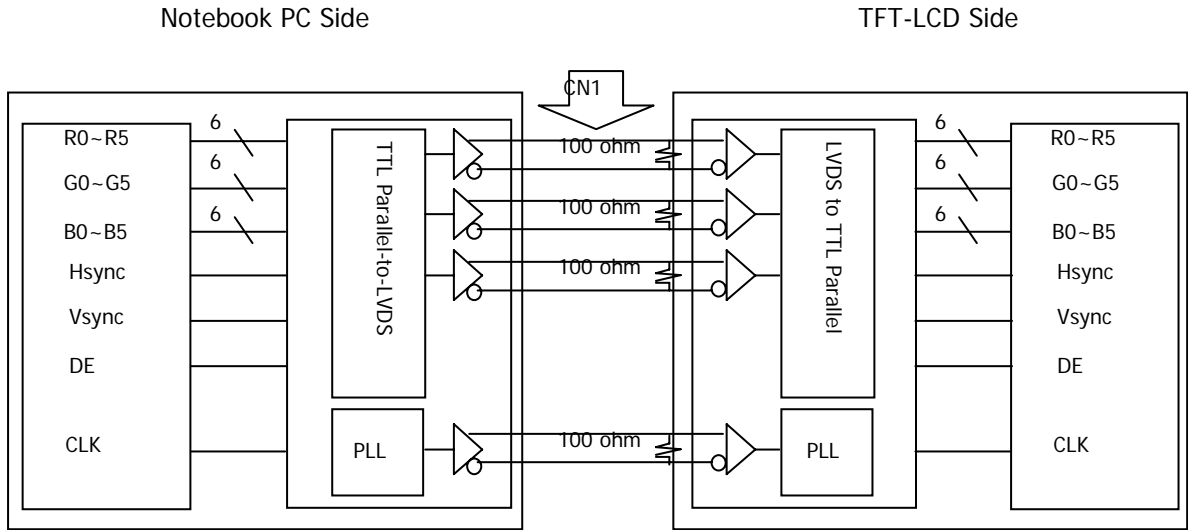

Note. Transmitter : Thine THC63LVDM63A or equivalent. Transmitter is not contained in Module.

**5.3.LVDS Input signal**

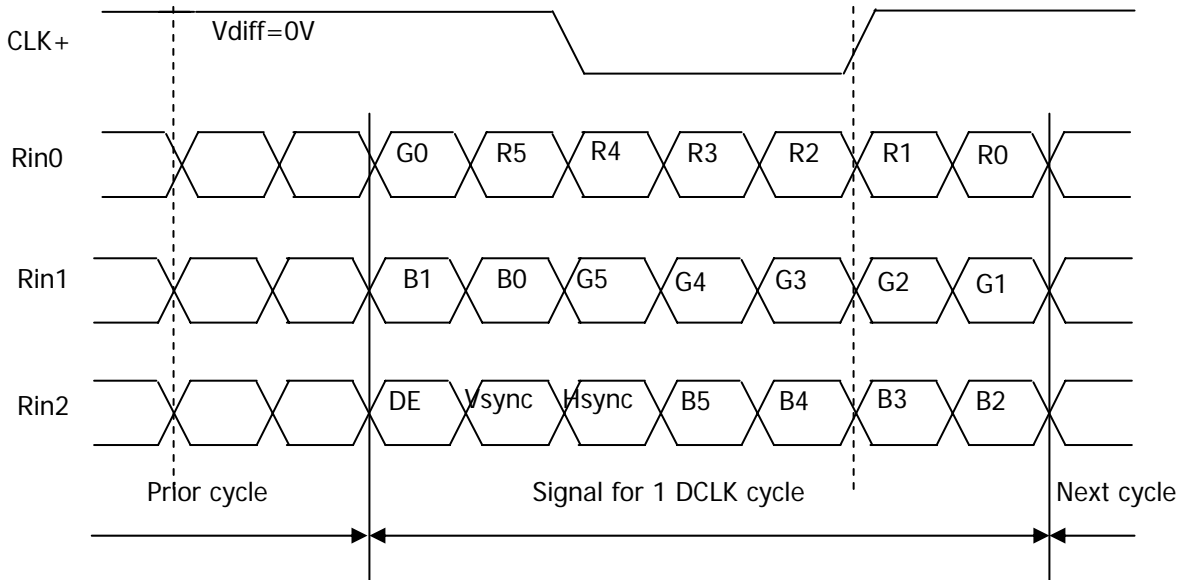

Note. Pin connection in case of using Thine THC63LVDM63A

<Table 6. Pin connection in case of using Thine THC63LVDM63A>

Input signal	Transmitter	Input signal	Transmitter
DCLK	CLK IN(TBD)	G4	TB3(TBD)
R0	TA0(TBD)	G5	TB4(TBD)
R1	TA1(TBD)	B0	TB5(TBD)
R2	TA2(TBD)	B1	TB6(TBD)
R3	TA3(TBD)	B2	TC0(TBD)
R4	TA4(TBD)	B3	TC1(TBD)
R5	TA5(TBD)	B4	TC2(TBD)
G0	TA6(TBD)	B5	TC3(TBD)
G1	TB0(TBD)	Hsync	TC4(TBD)
G2	TB1(TBD)	Vsync	TC5(TBD)
G3	TB2(TBD)	DE	TC6(TBD)

**5.4.Back-light Interface**

The Back-light interface connector is a model BHSR-02VS-1 manufactured by JST or equivalent. The connector interface pin assignments are listed in Table 7.

<Table 7. Back-light Electrical Interface>

Terminal No.	Symbol	Function	Color
1	VL	CCFL Power Supply (High Voltage)	Pink
2	GL	CCFL Power Supply (GND Side)	Black

**6.0. SIGNAL TIMING SPECIFICATION**

The specification of the signal timing parameters are listed in Table 8.

<Table 8. Signal Timing Specification.>

Item	Symbols	Min	Typ	Max	Unit
Frame Period	T1	1080	-	-	Lines
Vertical Display Period	T2	1050	-	-	Lines
One line Scanning Period	T3	1560	-	-	Clocks
Horizontal Display Period	T4	1400	-	-	Clocks
Clock Frequency	1/T5	-	101	110	MHz

**7.0 SIGNAL TIMING WAVEFORMS**

**7.1 Timing wave forms of interface signal**

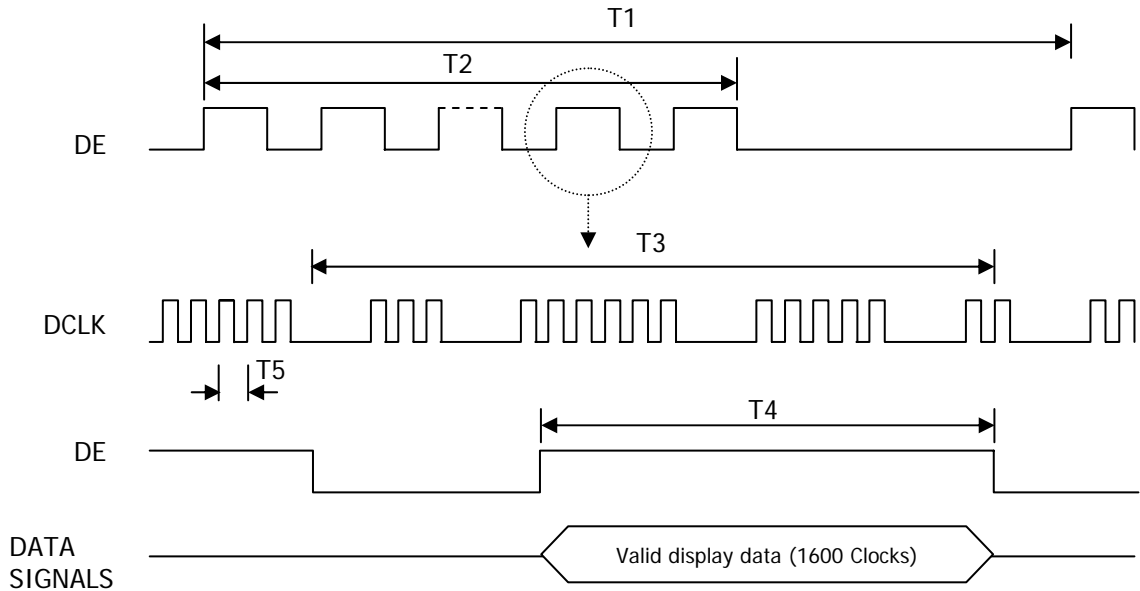



### 7.2 LVDS Rx Interface Timing Parameter

The specification of the LVDS Rx interface timing parameter is listed in Table 9.

<Table 9. LVDS Rx Interface Timing Specification>

Item	Symbol	Min	Typ	Max	Unit	Remark
PLL Set	tRPLL	-	-	10.0	msec	
CLKIN Period	tRIPC	11.77	12.35	21.16	nsec	
Input Data 0	tRIP0	-0.4	0.0	+0.4	nsec	
Input Data 1	tRIP1	tRIPC/7-0.4	tRIPC/7	tRIPC/7+0.4	nsec	
Input Data 2	tRIP2	2 × tRIPC/7-0.4	2 × tRIPC/7	2 × tRIPC/7+0.4	nsec	
Input Data 3	tRIP3	3 × tRIPC/7-0.4	3 × tRIPC/7	3 × tRIPC/7+0.4	nsec	
Input Data 4	tRIP4	4 × tRIPC/7-0.4	4 × tRIPC/7	4 × tRIPC/7+0.4	nsec	
Input Data 5	tRIP5	5 × tRIPC/7-0.4	5 × tRIPC/7	5 × tRIPC/7+0.4	nsec	
Input Data 6	tRIP6	6 × tRIPC/7-0.4	6 × tRIPC/7	6 × tRIPC/7+0.4	nsec	

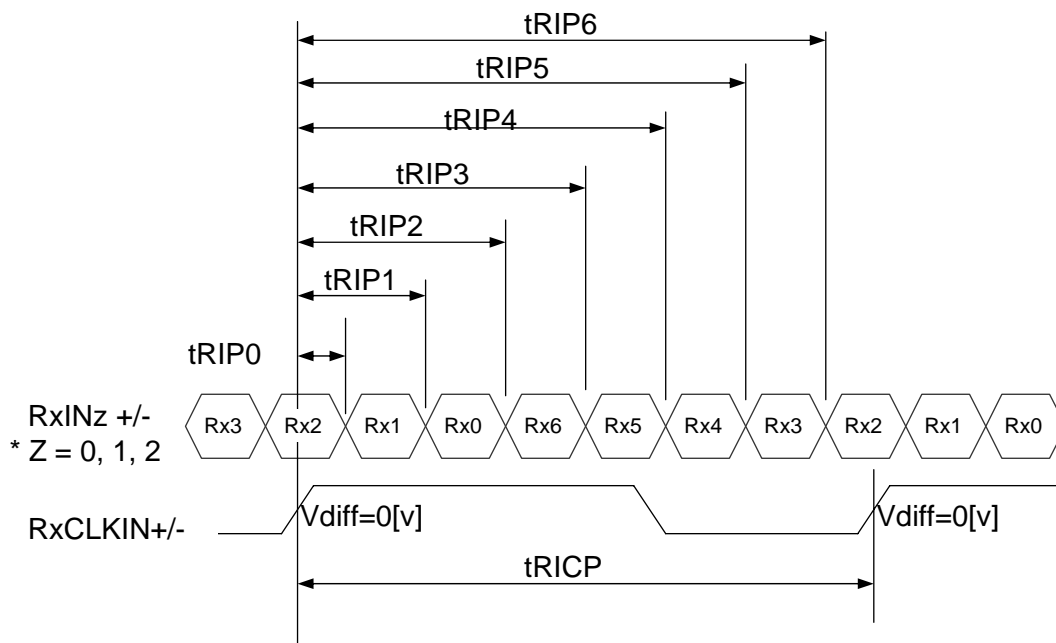

## 8.0 INPUT SIGNALS, BASIC DISPLAY COLORS & GRAY SCALE OF COLORS

Each color is displayed in 64 gray scales from a 6 bit data signal input. A total of 262,144 colors are derived from the resultant 18 bit data. Table 10. shows the input signals, basic display colors and gray scale for each color.

<Table 10. Input signals, Basic display colors and Gray scale for each color.>

	Colors & Gray scale	Data signal																	
		R0	R1	R2	R3	R4	R5	G0	G1	G2	G3	G4	G5	B0	B1	B2	B3	B4	B5
Basic colors	Black	0	0	0	0	0	0	0	0	0	0	0	0	0	0	0	0	0	0
	Blue	0	0	0	0	0	0	0	0	0	0	0	0	1	1	1	1	1	1
	Green	0	0	0	0	0	0	1	1	1	1	1	1	0	0	0	0	0	0
	Light Blue	0	0	0	0	0	0	1	1	1	1	1	1	1	1	1	1	1	1
	Red	1	1	1	1	1	1	0	0	0	0	0	0	0	0	0	0	0	0
	Purple	1	1	1	1	1	1	0	0	0	0	0	0	1	1	1	1	1	1
	Yellow	1	1	1	1	1	1	1	1	1	1	1	1	0	0	0	0	0	0
	White	1	1	1	1	1	1	1	1	1	1	1	1	1	1	1	1	1	1
Gray scale of Red	Black	0	0	0	0	0	0	0	0	0	0	0	0	0	0	0	0	0	0
	△	1	0	0	0	0	0	0	0	0	0	0	0	0	0	0	0	0	0
	Darker	0	1	0	0	0	0	0	0	0	0	0	0	0	0	0	0	0	0
	△																		
	▽																		
	Brighter	1	0	1	1	1	1	0	0	0	0	0	0	0	0	0	0	0	0
Gray scale of Green	Black	0	0	0	0	0	0	0	0	0	0	0	0	0	0	0	0	0	0
	△	0	0	0	0	0	0	1	0	0	0	0	0	0	0	0	0	0	0
	Darker	0	0	0	0	0	0	0	1	0	0	0	0	0	0	0	0	0	0
	△																		
	▽																		
	Brighter	0	0	0	0	0	0	1	0	1	1	1	1	0	0	0	0	0	0
Gray scale of Blue	Black	0	0	0	0	0	0	0	0	0	0	0	0	0	0	0	0	0	0
	△	0	0	0	0	0	0	0	0	0	0	0	0	1	0	0	0	0	0
	Darker	0	0	0	0	0	0	0	0	0	0	0	0	0	1	0	0	0	0
	△																		
	▽																		
	Brighter	0	0	0	0	0	0	0	0	0	0	0	0	1	0	1	1	1	1
Gray scale of White & Black	Black	0	0	0	0	0	0	0	0	0	0	0	0	0	0	0	0	0	0
	△	1	0	0	0	0	0	1	0	0	0	0	0	1	0	0	0	0	0
	Darker	0	1	0	0	0	0	0	1	0	0	0	0	0	1	0	0	0	0
	△																		
	▽																		
	Brighter	1	0	1	1	1	1	1	0	1	1	1	1	1	0	1	1	1	1
White	1	1	1	1	1	1	1	1	1	1	1	1	1	1	1	1	1	1	

## 9.0 POWER SEQUENCE

To prevent a latch-up or DC operation of the LCD module, the power on/off sequence shall be as shown in below

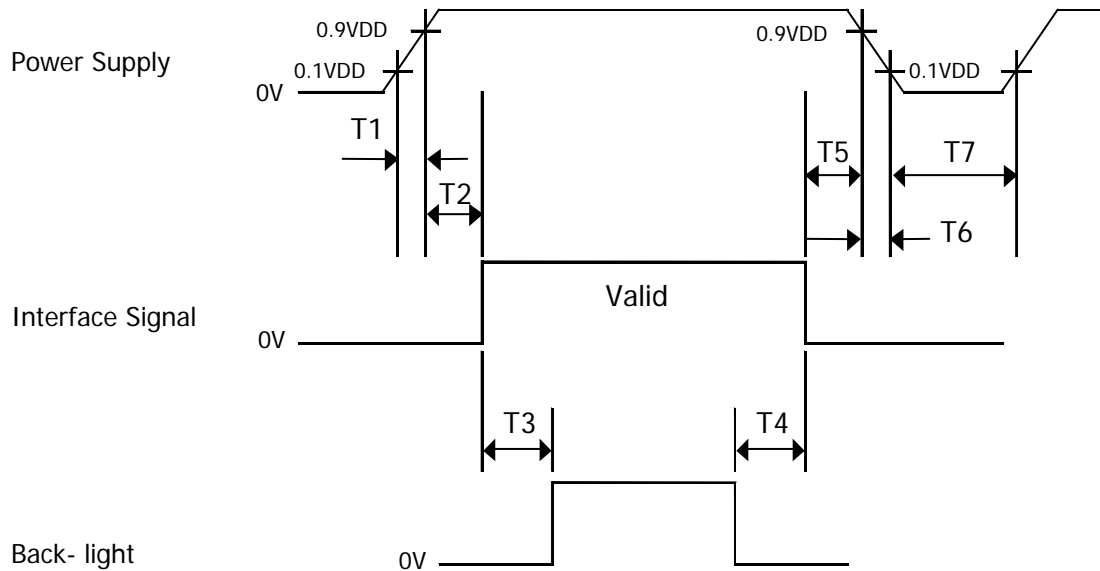

- $T1 \leq 10 \text{ ms}$
- $0 \leq T2 \leq 50 \text{ ms}$
- $200\text{ms} \leq T3$
- $0 \leq T4$
- $0 \leq T5$
- $0 \leq T6 \leq 10\text{ms}$
- $150\text{ms} \leq T7$

- Notes :
1. When the power supply VDD is 0V, Keep the level of input signals on the low or keep high impedance.
  2. Do not keep the interface signal high impedance when power is on.  
Back Light must be turn on after power for logic and interface signal are valid.

## 10.0 MECHANICAL CHARACTERISTICS

### 10.1 Dimensional Requirements

FIGURE 5 (located in Appendix) shows mechanical outlines for the model HV121P01-100. Other parameters are shown in Table 11.

<Table 11. Dimensional Parameters>

Parameter	Specification	Unit
Dimensional outline	270.0 ± 0.5 × 199.0 ± 0.5 4.8 Typ @ Lamp, 6.7 Typ @ Pouch	mm
Weight	305g (Typ.), 315g (Max.)	gram
Back-light	Connector : BHSR-02VS-1	
	CCFL, Horizontal & Bottom side lamp type	
	Length : 55.0 ± 5.0	mm

### 10.2 Mounting

See FIGURE 5. (shown in Appendix)

### 10.3 Anti-Glare and Polarizer Hardness.

The surface of the LCD has an anti-glare coating to minimize reflection and a coating to reduce scratching.

### 10.4 Light Leakage

There shall not be visible light from the back-lighting system around the edges of the screen as seen from a distance 50cm from the screen with an overhead light level of 350lux.

## 11.0 RELIABILITY TEST

The Reliability test items and its conditions are shown in table 12.

<Table 12. Reliability test>

No	Test Items	Conditions
1	High temperature storage test	Ta = 60 °C, 240 hrs
2	Low temperature storage test	Ta = -20 °C, 240 hrs
3	High temperature & high humidity operation test	Ta = 50 °C, 80%RH, 1000 hrs
4	High temperature operation test	Ta = 50 °C, 240hrs
5	Low temperature operation test	Ta = 0 °C, 1000hrs
6	Thermal shock	Ta = -20 °C ↔ 60 °C (0.5 hr), 100 cycle
7	Vibration test (non-operating)	1.5G, 10~200Hz for X,Y,Z axis 30 minutes for each axis
8	Shock test (non-operating)	210G, 3 ms, half sine (6 times) 50 G, 18ms, Trapezoidal
9	Electro-static discharge test (non-operating)	Air : 150 pF, 330Ω, 15 KV Contact : 150 pF, 330Ω, 8 KV

## 12.0 HANDLING & CAUTIONS

### (1) Cautions when taking out the module

- Pick the pouch only, when taking out module from a shipping package.

### (2) Cautions for handling the module

- As the electrostatic discharges may break the LCD module, handle the LCD module with care. Peel a protection sheet off from the LCD panel surface as slowly as possible.
- As the LCD panel and back - light element are made from fragile glass material, impulse and pressure to the LCD module should be avoided.
- As the surface of the polarizer is very soft and easily scratched, use a soft dry cloth without chemicals for cleaning.
- Do not pull the interface connector in or out while the LCD module is operating.
- Put the module display side down on a flat horizontal plane.
- Handle connectors and cables with care.

### (3) Cautions for the operation

- When the module is operating, do not lose CLK, ENAB signals. If any one of these signals is lost, the LCD panel would be damaged.
- Obey the supply voltage sequence. If wrong sequence is applied, the module would be damaged.

### (4) Cautions for the atmosphere

- Dew drop atmosphere should be avoided.
- Do not store and/or operate the LCD module in a high temperature and/or humidity atmosphere. Storage in an electro-conductive polymer packing pouch and under relatively low temperature atmosphere is recommended.

### (5) Cautions for the module characteristics

- Do not apply fixed pattern data signal to the LCD module at product aging.
- Applying fixed pattern for a long time may cause image sticking.

### (6) Other cautions

- Do not disassemble and/or re-assemble LCD module.
- Do not re-adjust variable resistor or switch etc.
- When returning the module for repair or etc., Please pack the module not to be broken. We recommend to use the original shipping packages.

**13.0 PACKING INFORMATION**

13.1 Packing order

Put Pad into the box.

Put silica gels in the box.

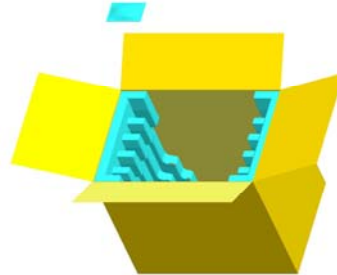
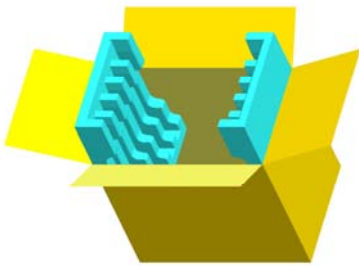

After sealing the box, attach Packing Label on the attach position sign area of the box.

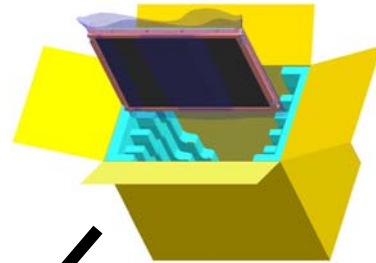

Place a cover on the top of the box.

As shown in the figure, place the Modules bundled by shielding bag in the box.

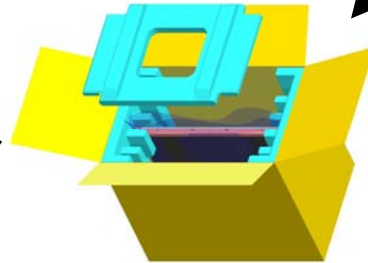

13.2 Notes

- Box Dimension: 349 mm(W) X 261 mm(D) X 311(H)
- Package Quantity in one Box: 10 pcs

**14.0 Label**

**14.1 Packing Label**

● Label size : 108 mm (L) X 56 mm (W)

● Contents

Model : HV121P01-100

Q'ty : Module Q'ty in one box

Serial No. : Box Serial No. See next figure for detail description

Date : Packing Date

FG Code : FG Code of Product

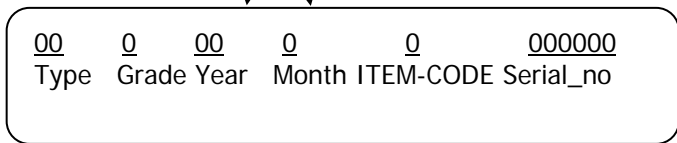
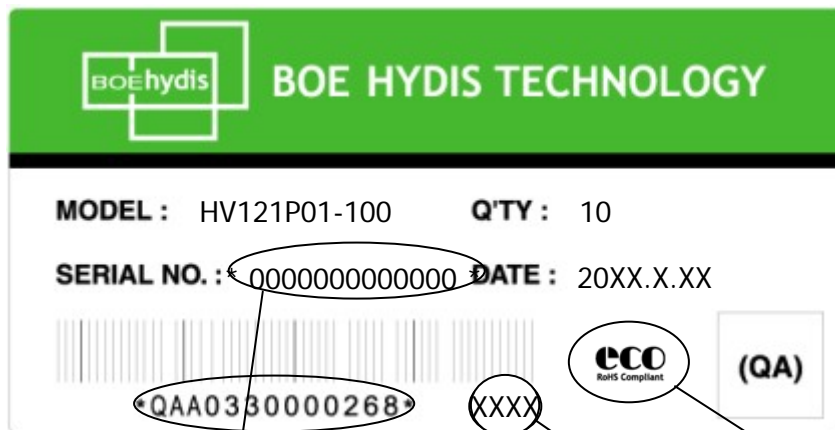

FG CODE

RoHS Mark

**14.2. High voltage caution label**

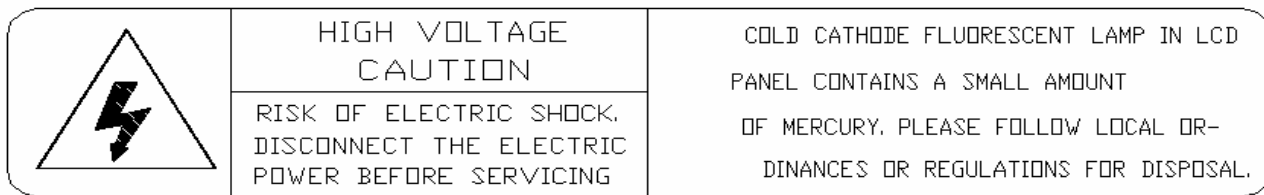



**14.3. Product Label**



**14.3.1 BOE HYDIS Barcode**

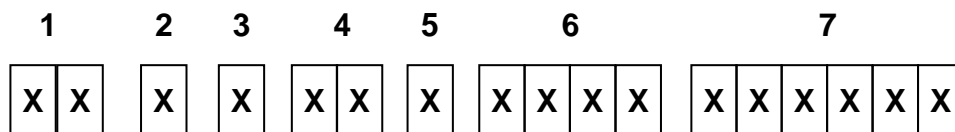

**Type Designation**

No 1. Control number

No 2. Rank / Grade

No 3. Company (H : BOE HYDIS, O : BOE OT)

No 4. Year (04 : 2004, 05 : 2005, ... )

No 5. Month (1, 2, 3, ... , 9, X, Y, Z)

No 6. Product Identification

No 7. Serial Number

**Figure 5. TFT-LCD Module Outline Dimension (Front View)**

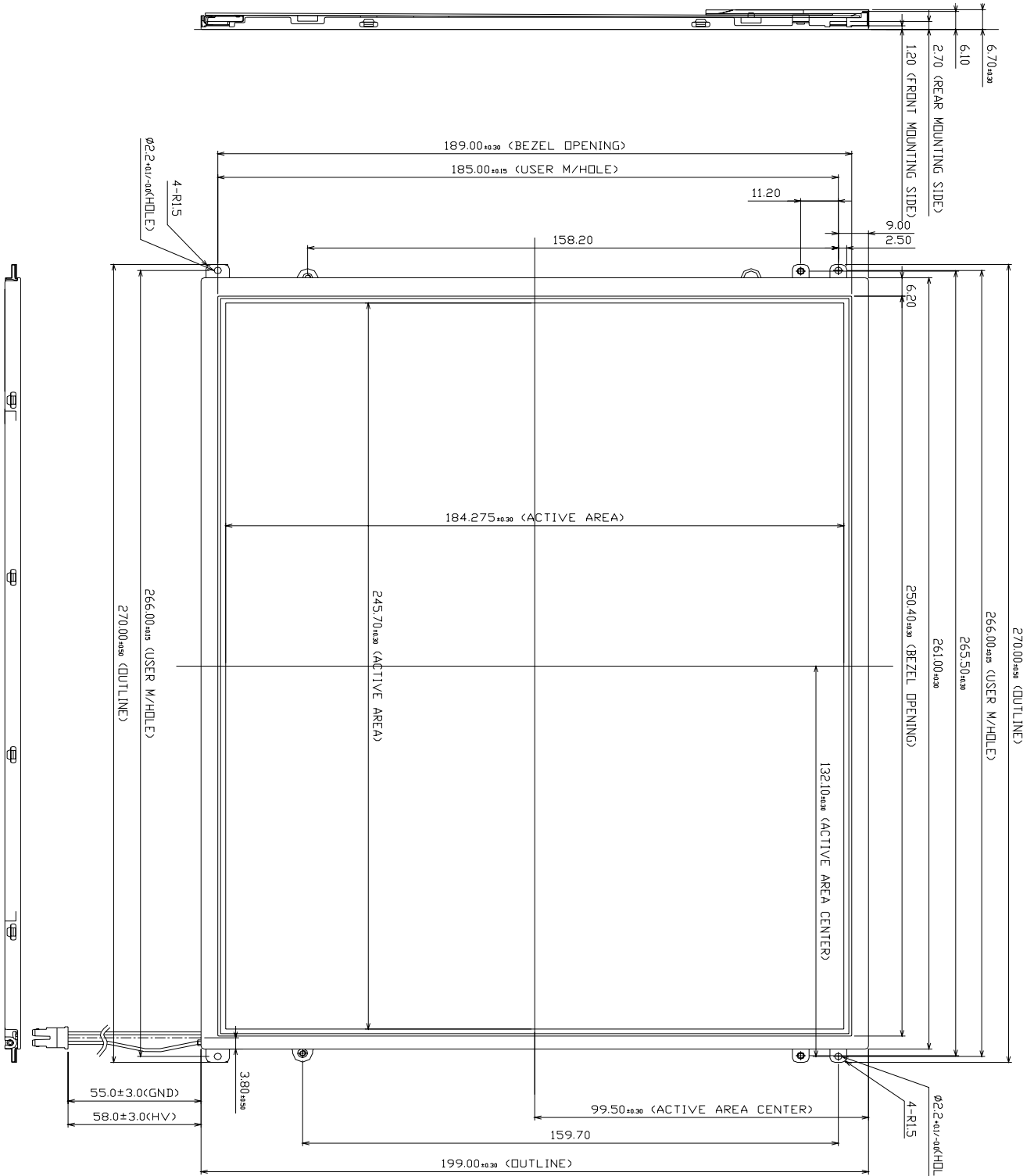

**Figure 6. TFT-LCD Module Outline Dimensions (Rear view)**

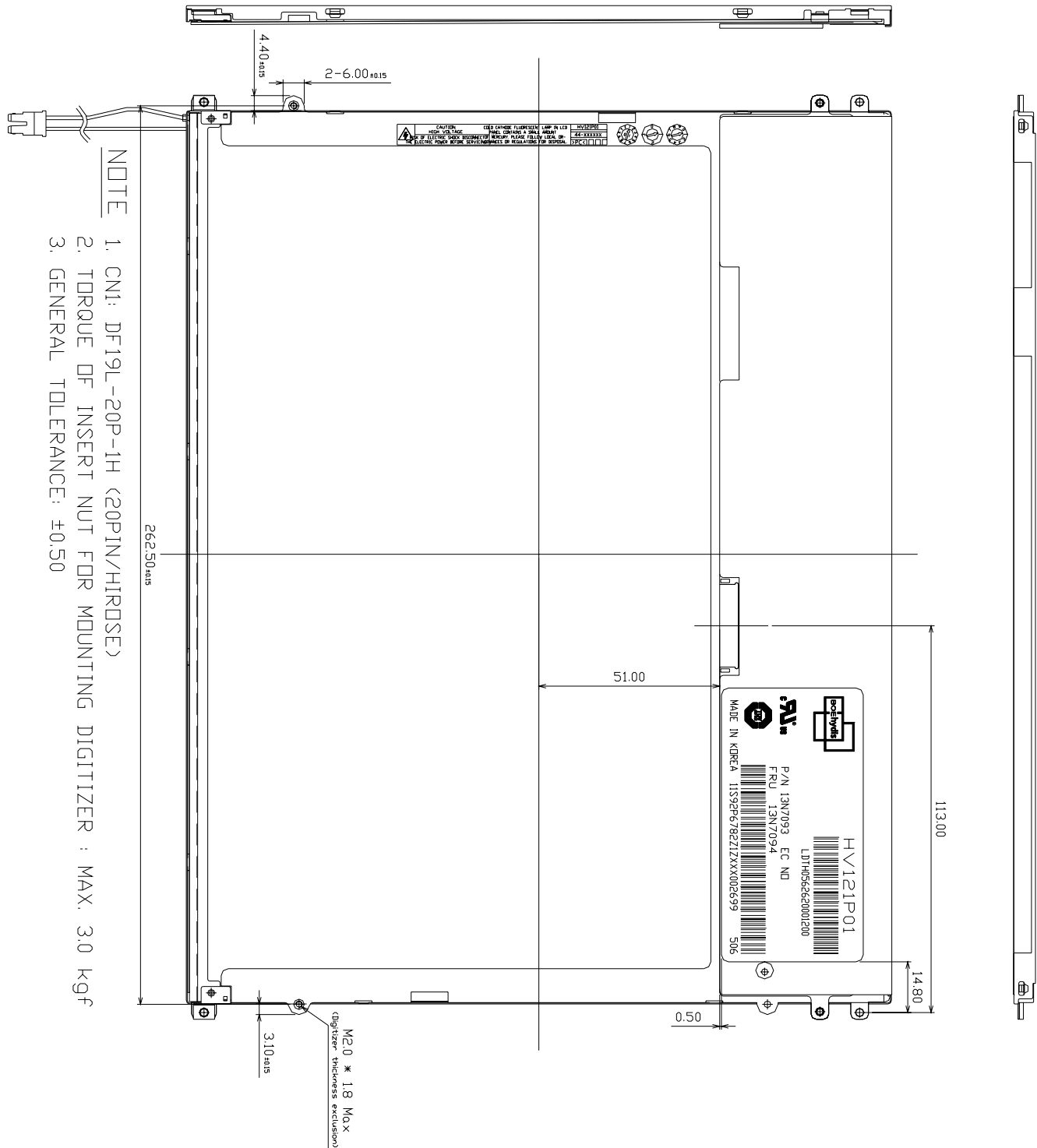

**NOTE**

1. CN1: DF19L-20P-1H (20PIN/HIROSE)
2. TORQUE OF INSERT NUT FOR MOUNTING DIGITIZER : MAX. 3.0 kgf
3. GENERAL TOLERANCE: ±0.50